

Laser Scan Analyzer (LSA-200B)

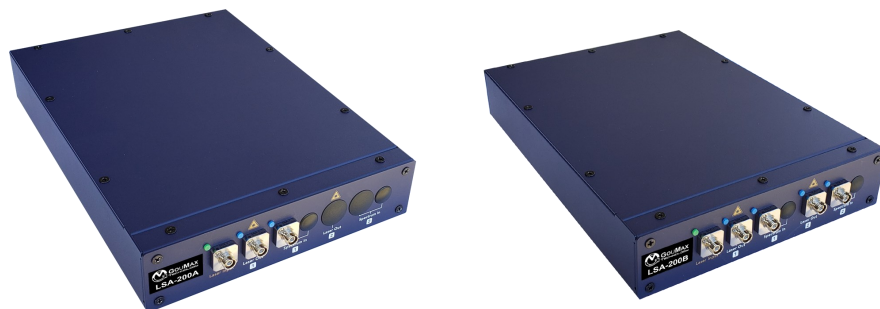

GouMax **Laser Scan Analyzer (LSA)** products are multi-function power meter modules. They are called "Laser Scan Analyzer" because LSA modules are usually used in various applications to measure powers in conjunction with laser scanning/sweeping. GouMax's LSA-200 modules are designed to allow the users to build their own automatic data collection/analysis systems by using their existing tunable lasers or GouMax TLS-1000/TLS-1200 tunable light sources. This lightweight measurement system can simultaneously test multiple devices at high speed with superior spectral resolution and high dynamic range. The LSA modules are aimed for fully utilizing the testing capacity of the tunable laser source and has significantly enhanced the production throughputs in manufacturing floor.

LSA-200A module is equipped with built-in power reference and supported by LSA-200A for wavelength reference. As exemplified in figure below, the light output of tunable laser source is inputted to a LSA module, which is connected to a device under test (DUT). The optical output from the DUT is directed to LSA's light detection unit. As the laser source scans the wavelength, the light-detection unit samples the light level passing through the DUT. Output spectrum data are referenced with built-in wavelength meter and power calibration. Within sub-second, the full spectrum of the DUT is acquired. Based on the referenced spectrum data, one can derive the critical parameters of the DUT, such as bandwidth at different levels, insertion loss, central wavelength and isolation, etc. To fulfill many varieties of customer's applications, LSA module provides Dynamic Link Library (DLL) that allows users to build their own control software while dynamically accessing acquisition data.

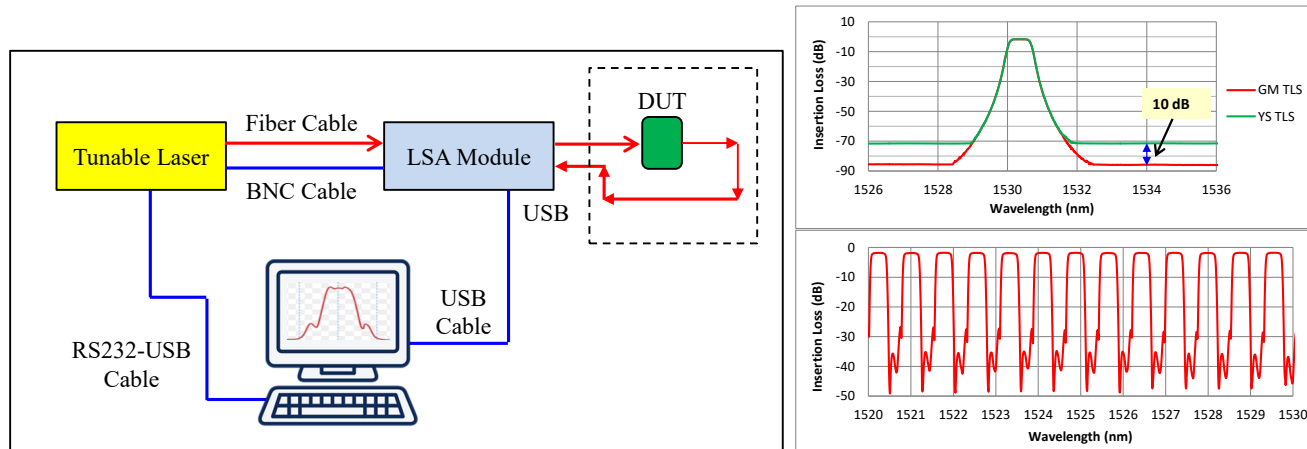

Laser Scan Analyzer (Two-Channel LSA-200B)

Key Features

- High-speed data acquisition unit
- Built-in wavelength reference
- Real-time power reference
- 70 dB dynamic range detection
- Dynamic Link Library (DLL)

Key Applications

- Passive fiber-optic component characterization
- Optical parameter measurement
- Production line automation
- Optical filter inspection
- Test and measurement instruments

LSA-200B Specifications and Key Parameters

Parameter	Unit	Specification	
		Type-R50	Type-R200
Operating Wavelength Range ¹⁾	nm	1250 ~ 1680	
Wavelength Accuracy	pm	±8	±20
Wavelength Repeatability ^{2), 3), 4)}	pm	4	10
Measurement Dynamic Range ⁵⁾	dB	>60	
Power Uncertainty ^{3), 4)}	dB	0.05	
Power Resolution ^{3), 4)}	dB	0.005	
Power Repeatability ^{2), 3), 4)}	dB	<±0.03	
Noise Floor	dBm	<-65	
Maximum Input Optical Power to Spectrum-In Port	dBm	~ 0	
Voltage to “Trigger In” BNC Port	V	3.1 ~ 5.0	
Voltage to “Sync Clock In” BNC Port	V	3.3	
Voltage to “PSG Trigger In” BNC Port	V	3.3	
Voltage to “Frequency Clock” BNC Port	V	3.3	
PD at Measurement Port #1	-	Internal or External	
PD at Measurement Port #2	-	Internal or External	
Optical Connector (Laser Input)		FC/APC	
Optical Connectors (Measurement Port #1 & #2)	-	FC/UPC	
Operating Temperature Range	°C	15 ~ 35	

Notes:

- 1) Determined by wavelength range of built-in wavelength meter and tunable laser sweeping wavelength range.
- 2) Measurement over 10 hours at temperature 25±1°C.
- 3) Laser power to Spectrum-In is > -10 dBm at temperature 25±1°C.
- 4) Measured at sweep speed 120 nm/s.